



LB30
LowBoy





DESCRIPTION (UNI 10929:2011) Self-Loading Concrete Mixer – Concrete net output 2,8 m³ (3,7 cubic yards) class S1 – Rear loading / unloading – N.4 wheel steering/drive – Loading by rigid bucket

ENGINE Perkins 1104D-44T, 4 stroke 4 cylinder - Turbo Diesel – Mechanical control with direct injection - Max Power 74,5 kW (101 hp) 2.300 RPM – Max torque 392 Nm 1.400 RPM - Water Cooled – Dry Air Filter - Conformity USA EPA Tier 3/EU STAGE IIIA

Deutz TCD3.6L04 – Diesel 4 stroke – N.4 cylinder in line - Turbo Aftercooled – Electronic Control – Common rail – Max. Power 74,4 kW (101 hp) a 2.300 RPM – Max. torque 410 Nm a 1.600 rpm – Water cooled – Dry air filter – Conformity EU STAGE IIIB/USA EPA Tier 4i

TRANSMISSION 4x4 full wheel drive, 4 speeds forward/reverse (2 hydraulic, 2 mechanic) - Max speed 40 Km/H - Max gradeability full loaded 50% - Hydrostatic “automotive” transmission with variable displacement pump and variable displacement 2 position hydraulic motor controlled by an electro-hydraulic lever for “slow”/“fast” speed selection and reverse movement - Mechanical gearbox for “work” and “transfer” speed with electro-hydraulic control lever – Inching Pedal

AXLES Both load-bearing and steering with planetary reduction gears on the wheel hubs – Front axle oscillating at 10° – Rear axle fixed with flanged gearbox

BRAKES Hydraulic internal oil-bath disc service brake acting on all 4 wheels activated by a dual circuit independent pump – Hydraulic internal oil-bath disc parking brake acting directly on rear axle with hydraulic control negative – Emergency brake incorporated directly in service brake

STEERING Hydrostatic fed by an independent pump - Four wheel steering by means of 2 double action cylinders - Steering selector device on operator’s console for: front wheel drive/ 4 wheel bi-lateral drive/ 4 wheel parallel drive (crab mode)

FRAME Electrically welded high-tempered steel – Hydraulic drum lifting control by means of double-acting cylinder - High capacity hopper – Unloading chute with hydraulic tilting by means of a double-acting cylinder controlled both from operator’s turret and ground - Manual 180° chute rotation

DRUM with big double spiral mixing blades, double cone and convex bottom - Emergency manhole for inspection or emergency unloading - Drum rotation by means of a hydrostatic transmission with variable displacement pump and orbital motor coupled to gearbox with infinitesimal electro-hydraulic control both from the operator’s turret and ground - Geometric volume 3700 Lt (976 gals) - Max concrete yield 2,8 m³ (3,7 cubic yards) S1 class – Drum speed 27 RPM – Drum raising by means of a double-acting lift cylinder for quick unloading

BUCKET Rigid high inclined bucket for fast and hassle free aggregates discharge positioned on a loading arm driven by 2 double-acting hydraulic cylinders – Capacity 600 Lt (158 gals.) – Single lever control – 11 m³/hour productivity

OPERATOR’S TURRET Rotating, mounted on ball-bearing swivel ring - Anatomic seat with flexible suspension and height adjustment, seat belts - Large high visibility windshield with electric wiper – Steering column in ABS with electronic display and ergonomic user friendly dashboard and control panels - 2 sides enclosed ROPS FOBS cabin (optional total closure cab)

HYDRAULIC SYSTEM 3-element hydraulic distributor – Piston variable displacement pump 37Lt @ 1000 RPM for drum rotation – Gear pump 26Lt @ 1000 RPM for utilities - Gear pump 20Lt @ 1000 RPM for steering and breaks - Oil 10 µm filter on hydrostatic intake circuit - N 2 25 µm filters on hydraulic intake circuit

WATER SYSTEM Self-priming volumetric water pump with quick-suction activated by hydraulic motor controlled both from the driver’s seat and from the ground – Flow rate 500 Lt/min. (131 gals.) - Max head 2,2 bar – 2 water tanks with total capacity approx. 500 Lt (145 gals) – Quick-coupling water intake hoses with filter - Cleaning hose – Electronic water meter

ELECTRICAL SYSTEM Starter 12V- 3 kW - Alternator 12V 95A with regulator incorporated - Battery 12V 110Ah (900A).

GROUND COMMANDS Water meter and water pump commands, drum rotation, chute up/down commands, emergency stop

SERVICE REFILL CAPACITIES

Fuel tank	90 l
Total hydraulic system capacity	120 l
Engine oil	9,5 l
Engine cooling liquid	7,0 l

TIRES 12.5/80-18 16 PR

DIMENSIONS 2.000 (78.8 inches) x6.110 (240.73 inches) x2.600 mm (102.44 inches)
(bucket down)

WEIGHT on road 4.900 kg (10.802 lbs)

MEETS CEE road standards

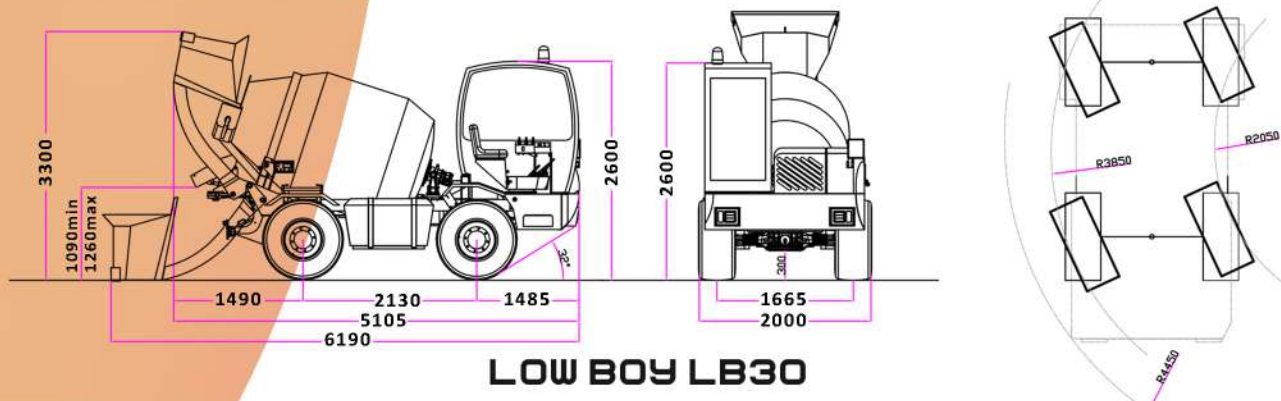



Spirit of Excellence

AMOG srl | 180031 Brusciano (Na) Italy | Tel. +39 081 6588361 | sales@davinogroup.biz
davinomixer.com